

# FORGED FLOATING BALL VALVE SERIES

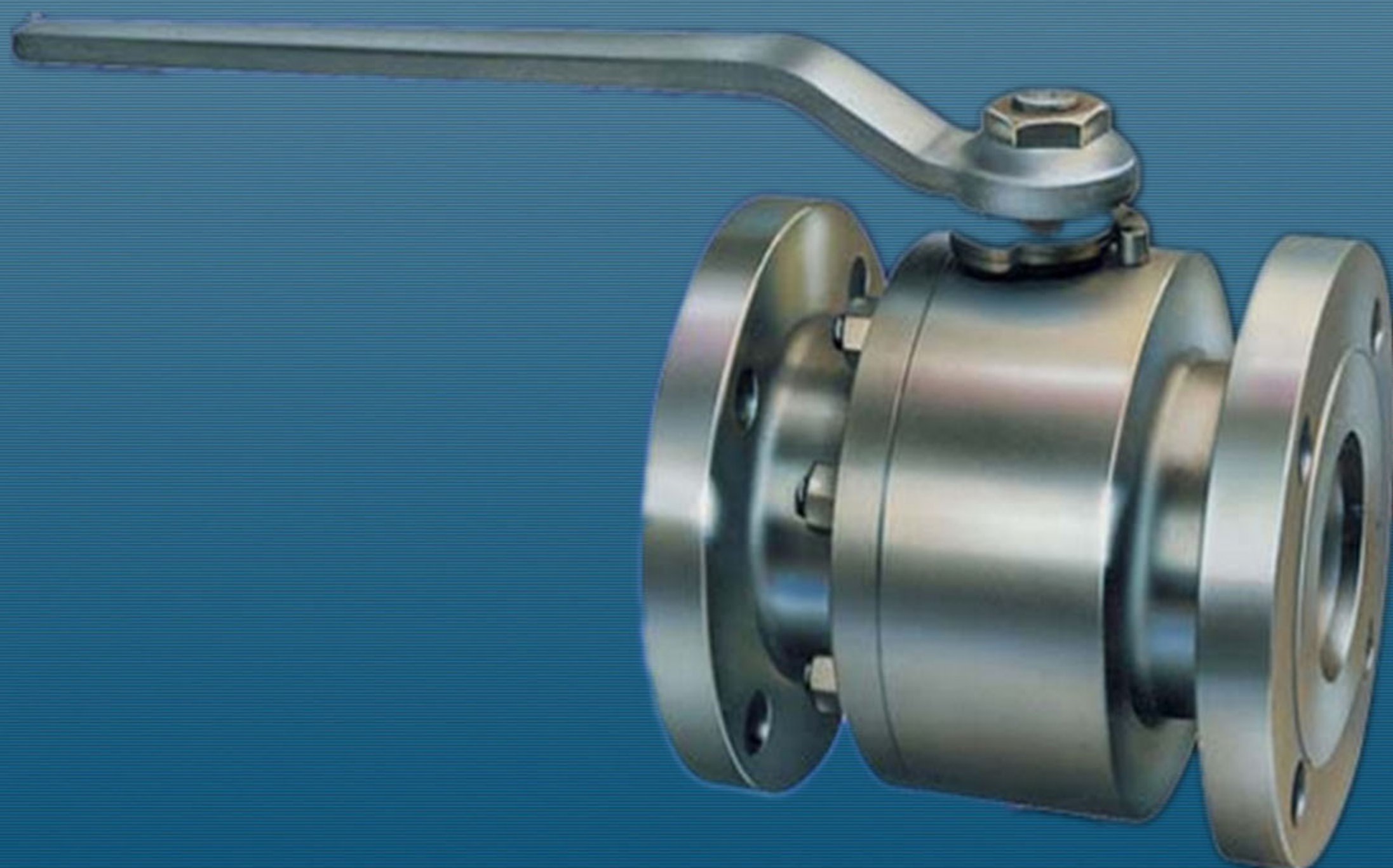

[www.seekovalve.com](http://www.seekovalve.com)



# FORGED FLOATING BALL VALVE

## STRUCTURAL FEATURES

### 1、 Special Seat Design

The floating ball valve adopts the design of flexible seal ring structure. When the medium pressure is lower, the contact area of seal ring and ball is smaller, so higher sealing ratio is formed at the place where the seal ring and ball contact to ensure reliable sealing. When the

medium pressure is higher, the contact area of seal ring and ball becomes bigger along with the elastic deformation of seal ring, so the seal ring can endure higher medium thrust without being damaged.

#### Elastic Seat

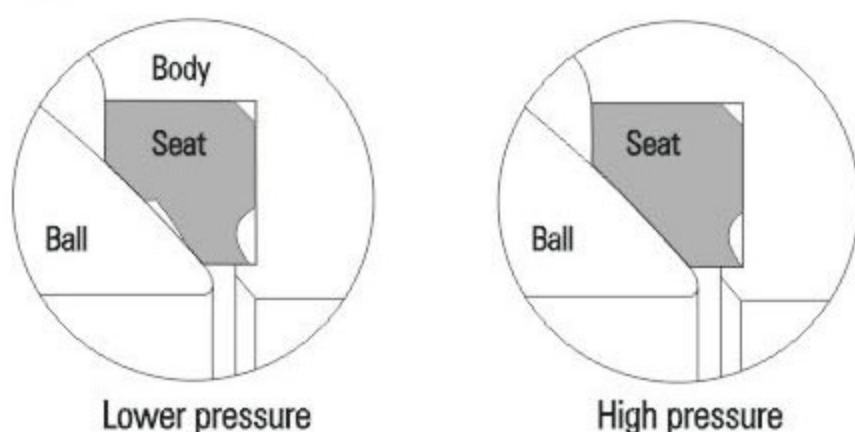

### 2、 Fireproof Structure Design

In case of fire during the use of valve, the seat ring made of PTFE or other non-metal materials will be decomposed or damaged under high temperature and cause higher leakage. The fireproof seal ring is set between ball and seat so that after the valve seat is burnt, the medium will push the ball rapidly towards the downstream metal seal ring to form the auxiliary metal to metal sealing structure,

which can effectively control valve leakage. In addition, the middle flange sealing gasket is made of metal wound gasket, which can ensure sealing even under high temperature. The fireproof structure design of floating ball valve conforms to requirements in API 607, API 6FA, BS 6755 and other standards.

#### Fireproof Structure Design Of Seat

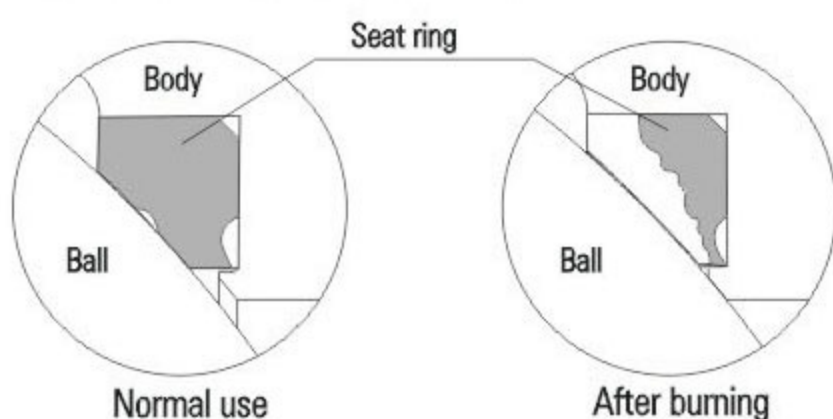

#### Fireproof Structure Of Middle Flange

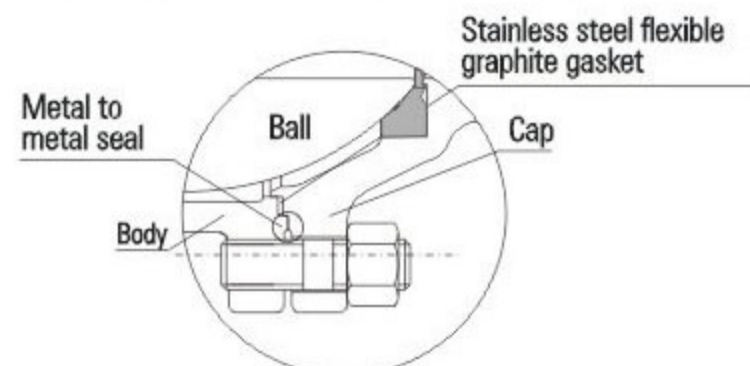

#### Fireproof Structure Design Of Stem

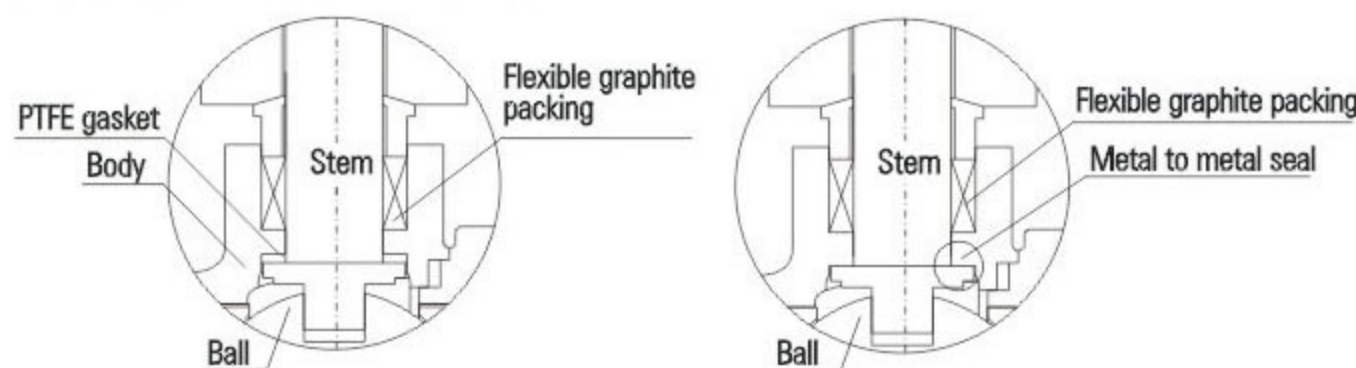

# FORGED FLOATING BALL VALVE

## STRUCTURAL FEATURES

### 3、Reliable Sealing Of Valve Stem

The stem is provided with the shoulder at its bottom so that it will not be blown out by the medium even under the extreme conditions such as abnormal pressure rise inside the valve cavity, failure of gland plate and etc. In addition, to avoid leakage after the stem packing is burnt in case of fire, the thrust bearing is set at the place where the stem shoulder and body contact to form a

reverse sealing seat. The sealing force of the reverse seal will increase according to the increase of medium pressure, so as to ensure reliable stem sealing under various pressure, prevent leakage and avoid accident spreading.

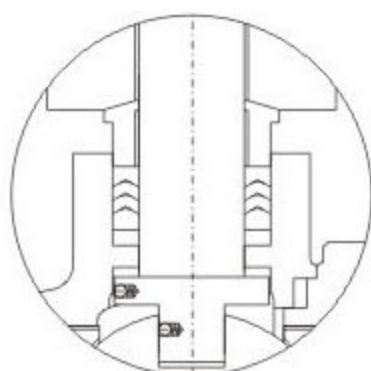

The bottom-mounted stem will not be blown out by medium pressure.

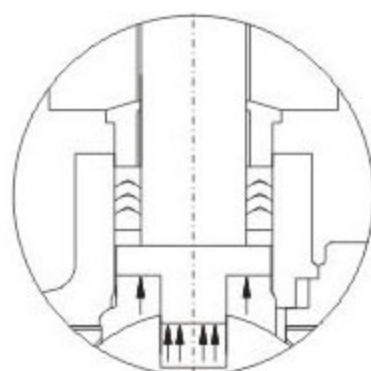

The top-mounted stem may be blown out by medium pressure.

The stem adopts V type packing sealing structure. The V type packing can effectively change the pressing force and medium force of the gland into the sealing force of the stem.

According to user requirements, the disc spring loaded packing pressing mechanism can be adopted to make the sealing of stem packing more reliable.

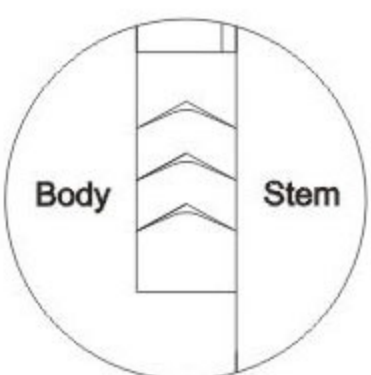

Before the packing is pressed

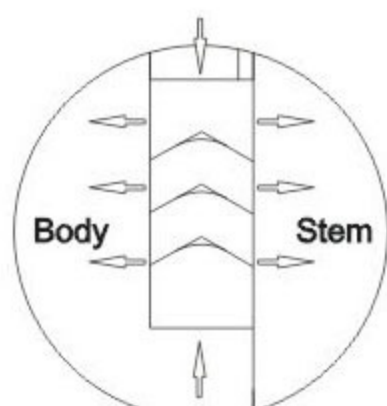

After the packing is pressed

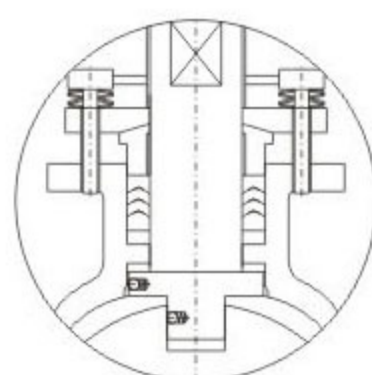

The disc spring loaded packing pressing mechanism is adopted.



# FORGED FLOATING BALL VALVE

## STRUCTURAL FEATURES

### 4、 Anti-static Structure

The ball valve is provided with the anti-static structure and adopts the static electricity discharge device to directly form a static channel between the ball and body or form a static channel between the ball and body through the stem, so as to discharge the static electricity

produced due to friction during the opening and closing of ball and seat through the pipeline, avoiding fire or explosion that may be caused by static spark and ensuring system safety.

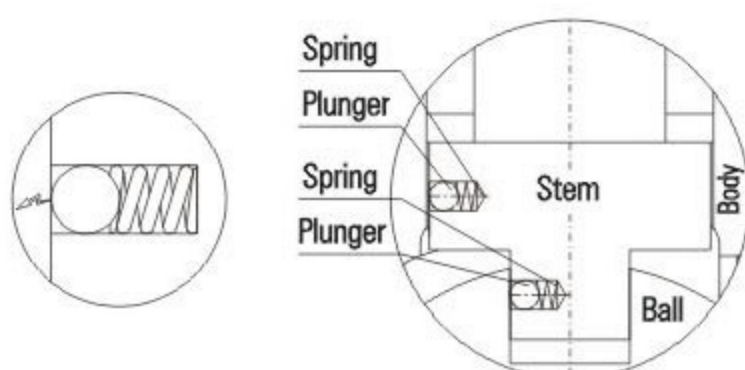

Anti-static structure design of ball valve with  $Dn \geq 32$

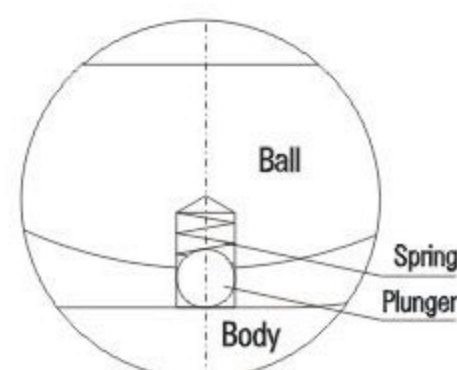

Anti-static structure design of ball valve with  $Dn \leq 25$

### 5、 Lock And Misoperation Prevention

The manual ball valve can be locked by a lock when it is at the full open or full close position. The 90° open and close positioning piece with lock hole is designed to avoid valve misoperation caused due to handle operation by non-operators, and it can also prevent valve opening or closing, or other accidents caused by pipeline vibration or unpredictable factors. It is very effective especially for inflammable and explosive oil, chemical and medical

working pipelines or field tubing. The part on the head of the stem that is installed with the handle adopts flat design. When the valve is opened, the handle is parallel to the pipeline, and when the valve is closed, the handle is vertical to the pipeline, so that the opening and closing indications of the valve are guaranteed to have no error.

#### Lock And Misoperation Prevention Structure

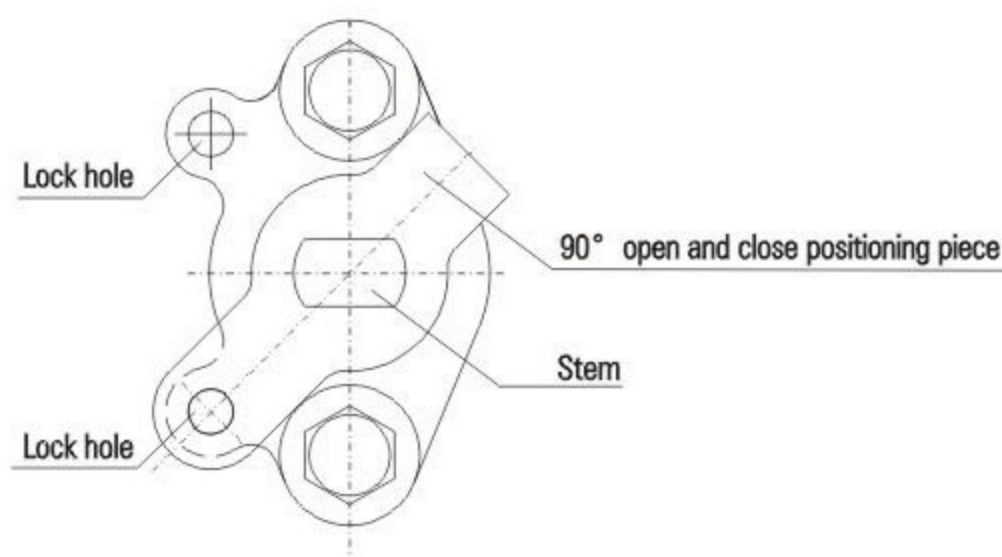

# FORGED FLOATING BALL VALVE

1	Body
2	Stud
3	Ball
4	Seat
5	Anti-fire gasket
6	Bonnet
7	Anti-static device
8	Stem
9	Thrust bearing
10	Sliding bearing
11	O ring
12	Anti-fire gasket
13	Seal gland
14	Socket head cap screw
15	Packing
16	Packing bushing
17	Packing gland
18	Socket head cap screw
19	Stopper
20	Retainer ring
21	Hexagon nut

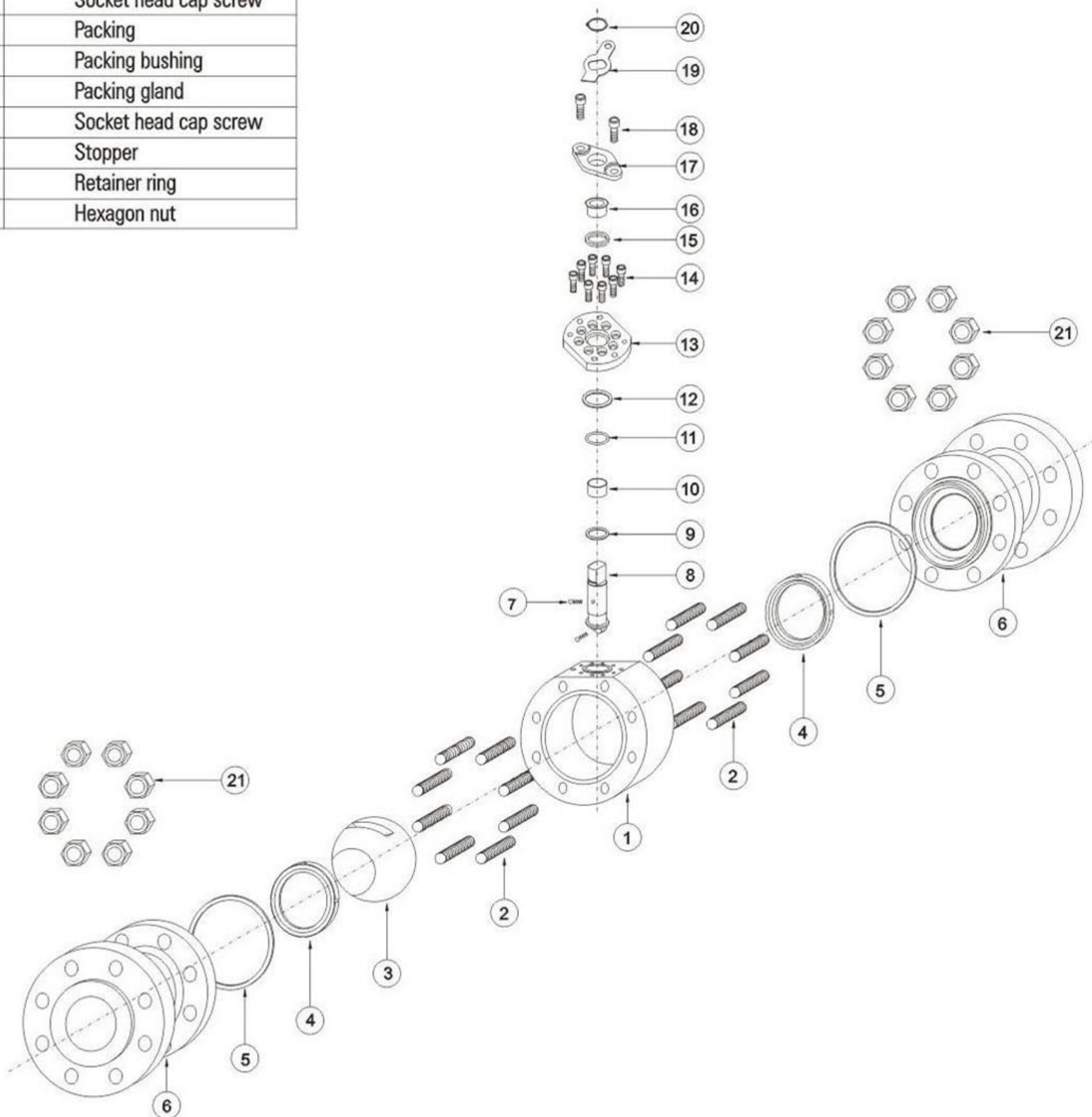
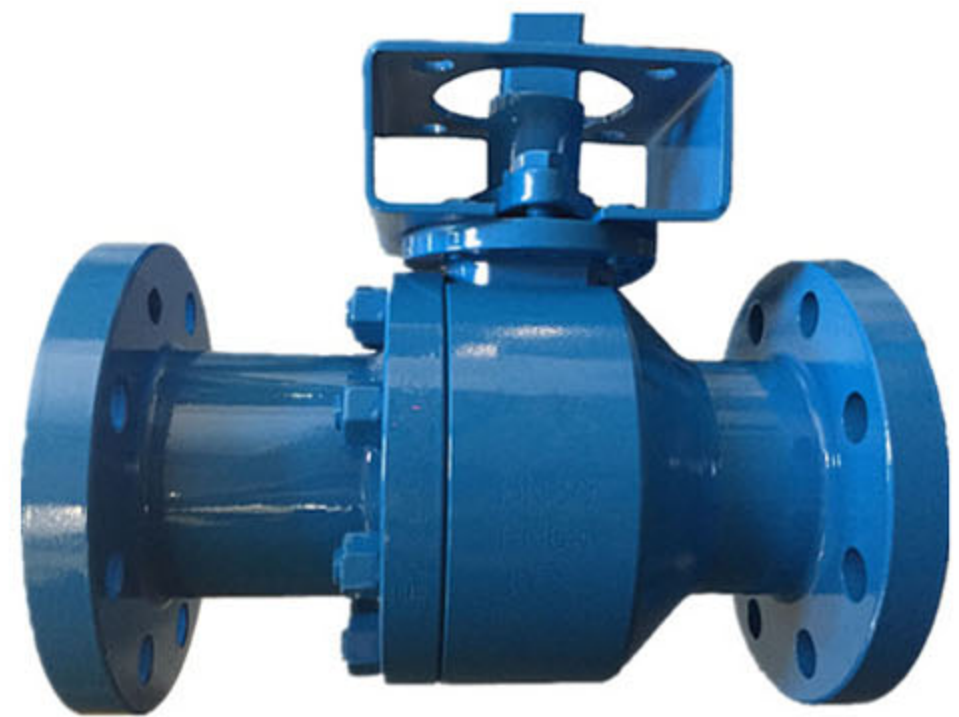



# FORGED FLOATING BALL VALVE

## Part Materials And Main Parameters

Nominal diameter (in)		NPS 1/2~8					
Nominal pressure (MPa)		Class150~Class600					
No.	Part Name	Material					
		Carbon steel	Stainless steel				
1	Body	ASTM A105	ASTM A182 304	ASTM A182 316	ASTM A182 304L	ASTM A182 316L	
2	Stud	A193 B7M	A320 B8	A320 B8M	A320 B8	A320 B8M	
3	Ball	ASTM A105 • ENP	ASTM A182 304	ASTM A182 316	ASTM A182 304L	ASTM A182 316L	
4	Seat	PTFE/NYLON/PEEK/PPL					
5	Anti-fire gasket	SST+Graphite					
6	Bonnet	ASTM A105	ASTM A182 304	ASTM A182 316	ASTM A182 304L	ASTM A182 316L	
7	Anti-static device	Combined parts	Combined parts	Combined parts	Combined parts	Combined parts	
8	Stem	ASTM A182 F6a	ASTM A182 304	ASTM A182 316	ASTM A182 304L	ASTM A182 316L	
9	Thrust bearing	PTFE					
10	Sliding bearing	PTFE					
11	O ring	VITON					
12	Anti-fire gasket	SST+Graphite					
13	Seal gland	ASTM A105 • ENP	ASTM A182 304	ASTM A182 316	ASTM A182 304L	ASTM A182 316L	
14	Socket head cap screw	A193 B7M	A320 B8	A320 B8M	A320 B8	A320 B8M	
15	Packing	Graphite					
16	Packing bushing	ASTM A182 F6a	ASTM A182 F6a	ASTM A182 F6a	ASTM A182 F6a	ASTM A182 F6a	
17	Packing gland	ASTM A216 WCB	ASTM A216 WCB	ASTM A216 WCB	ASTM A216 WCB	ASTM A216 WCB	
18	Socket head cap screw	A193 B7M	A193 B7M	A193 B7M	A193 B7M	A193 B7M	
19	Stopper	A3.Zn	A3.Zn	A3.Zn	A3.Zn	A3.Zn	
20	Retainer ring	65Mn	65Mn	65Mn	65Mn	65Mn	
21	Hexagon nut	A194 2H	A194-8	A194 -8M	A194-8	A194-8M	
Applicable service conditions	Applicable media	Water, steam, oil, gas liquefied gas, natural gas, etc.	Nitric acid	Acetic acid	Strong oxidizer	Urea	
	Applicable temperature	≤120°C (PTFE) 、 ≤80°C (NYLON) 、 ≤250°C (PEEK) 、 ≤250°C (PPL)					
Design and manufacturing		API 608					
Face-to-face dimensions		ASME B16.10					
Type of connection		Flange	ASME B16.5		Butt welding	ASME B16.25	
Pressure test		API 598					
Transmission moe		Manual, worm and worm gear transmission, pneumatic, electric					



# FORGED FLOATING BALL VALVE

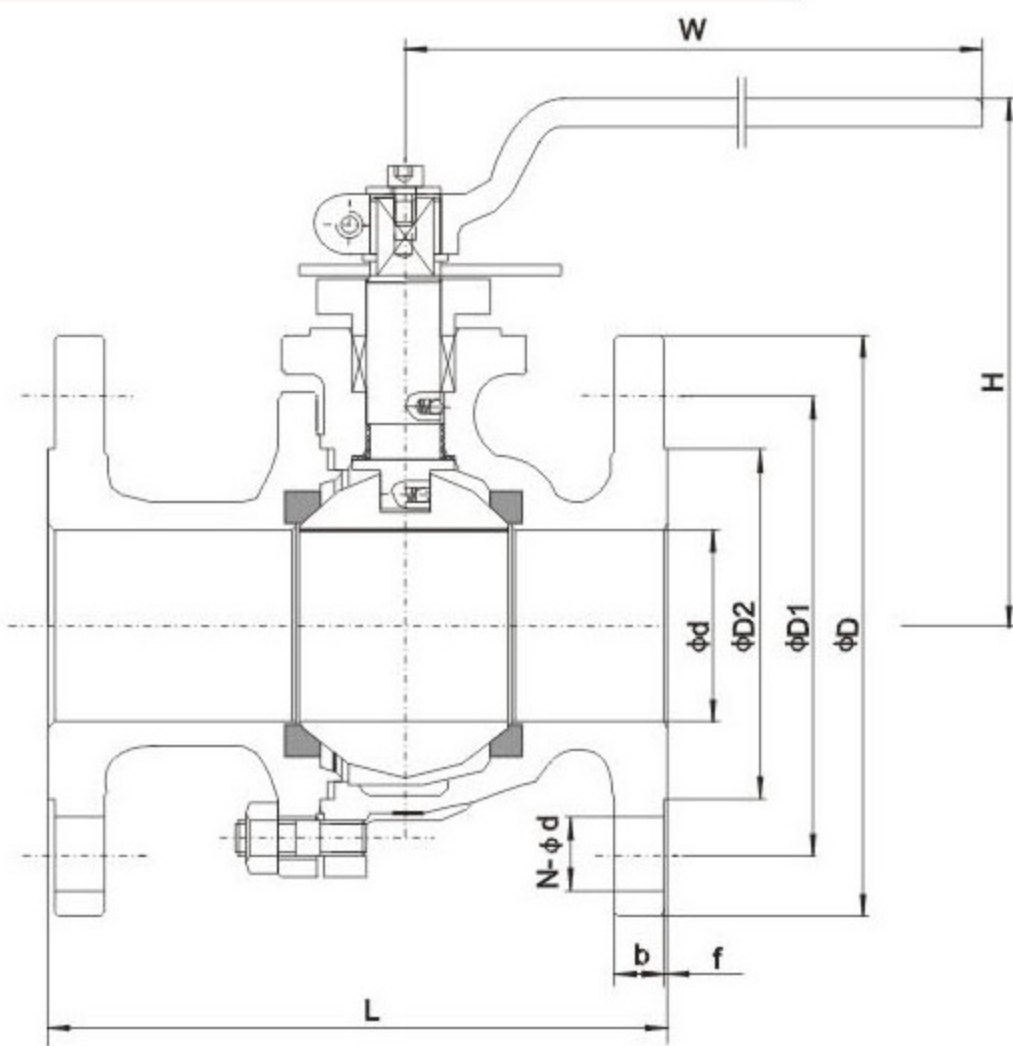

Floating cast steel ball valve

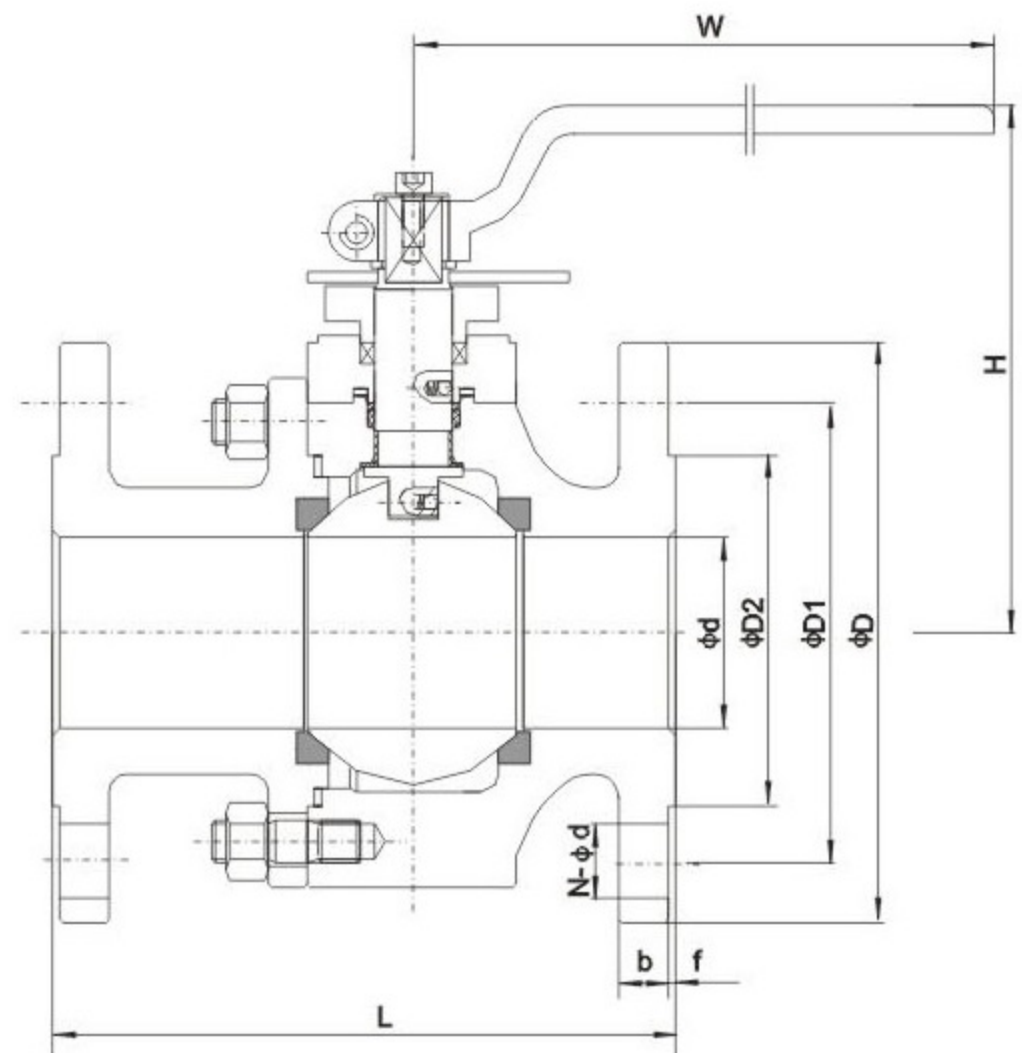

Floating forged steel ball valve

Pressure rating	Nominal Diameter		d	Flanged		Butt welding	Raised face flange						W	Cast steel	Forged steel	Weight(kg)		
	Class	NPS		DN	L(RF)		L(RTJ)	L(BW)	D	D1	D2	f				b	N-φd	H
150		1/2"	15	13	108	-	140	90	60.5	35	2	9	4-φ16	140	80	78	2	△
		3/4"	20	19	117	-	152	100	70	43	2	10	4-φ16	140	86	82	2.5	△
		1"	25	25	127	-	165	110	79.5	51	2	11	4-φ16	140	98	95	3.5	△
		1 1/4"	32	32	140	-	178	115	89	64	2	11	4-φ16	180	106	100	6.5	△
		1 1/2"	40	38	165	-	190	125	98.5	73	2	13	4-φ16	180	133	128	7.5	△
		2"	50	50	178	191	216	150	120.5	92	2	14.5	4-φ19	200	138	137	9	△
		3"	80	75	203	216	283	190	152.5	127	2	17.5	4-φ19	300	175	148	19	△
		4"	100	100	229	241	305	230	190.5	157	2	22.5	8-φ19	650	235	223	36	△
		6"	150	150	394	406	457	280	241.5	216	2	24	8-φ22	800	285	278	79	△
	8"	200	201	457	470	521	345	298.5	270	2	27	8-φ22	1000	342	336	160	△	
300		1/2"	15	13	140	-	140	95	66.5	35	2	13	4-φ16	140	80	78	2.5	△
		3/4"	20	19	152	-	152	115	82.5	43	2	14.5	4-φ19	140	86	82	3.6	△
		1"	25	25	165	-	165	125	89	51	2	16	4-φ19	140	98	95	5	△
		1 1/4"	32	32	178	-	178	135	98.5	64	2	17.5	4-φ19	180	106	100	8.5	△
		1 1/2"	40	38	190	-	190	155	114.5	73	2	19.5	4-φ22	180	133	128	10	△
		2"	50	50	216	232	216	165	127	92	2	21	8-φ19	200	138	137	12	△
		3"	80	75	283	298	283	210	168.5	127	2	27	8-φ22	300	175	148	28	△
		4"	100	100	305	321	305	255	200	157	2	30.5	8-φ22	650	235	223	46	△
		6"	150	150	403	419	457	320	270	216	2	35	12-φ22	800	285	278	104	△
	8"	200	201	502	518	521	380	330	270	2	40	12-φ25	1000	342	336	208	△	
600		1/2"	15	13	165	-	165	95	66.5	35	7	14.5	4-φ16	140	78	68	5	△
		3/4"	20	19	190	-	190	115	82.5	43	7	16	4-φ19	140	80	76	7	△
		1"	25	25	216	-	216	125	89	51	7	17.5	4-φ19	180	110	106	9	△
		1 1/4"	32	32	229	-	229	135	98.5	64	7	21	4-φ19	200	115	110	13	△
		1 1/2"	40	38	241	-	241	155	114.5	73	7	22.5	4-φ22	250	135	128	17	△
		2"	50	50	292	295	292	165	127	92	7	26	8-φ19	300	152	140	21	△
		3"	80	75	356	359	356	210	168.5	127	7	32	8-φ22	650	224	213	43	△
		4"	100	100	432	435	432	275	216	157	7	38.5	8-φ25	800	248	238	85	△

△ Please consult the factory:

Note: The weight value is only for flanged valve. Please consult our factory for higher nominal diameter or weight. Any modification to sizes H, H1 and weight will not be notified otherwise.



# FORGED FLOATING BALL VALVE

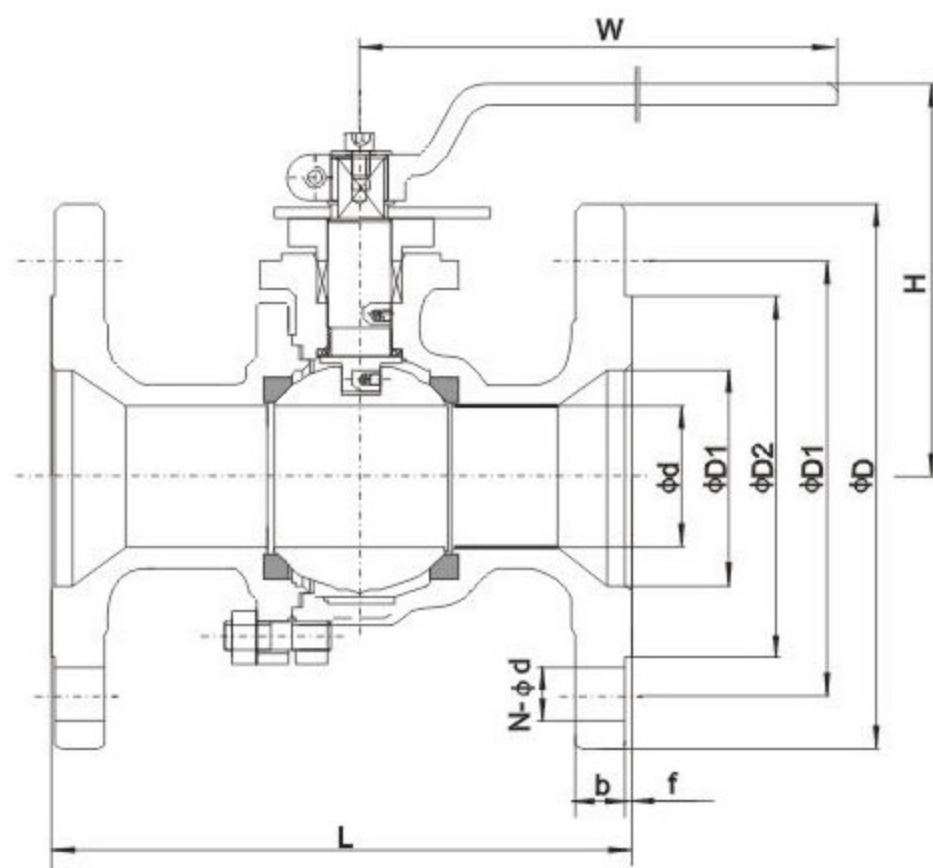

Floating cast steel ball valve

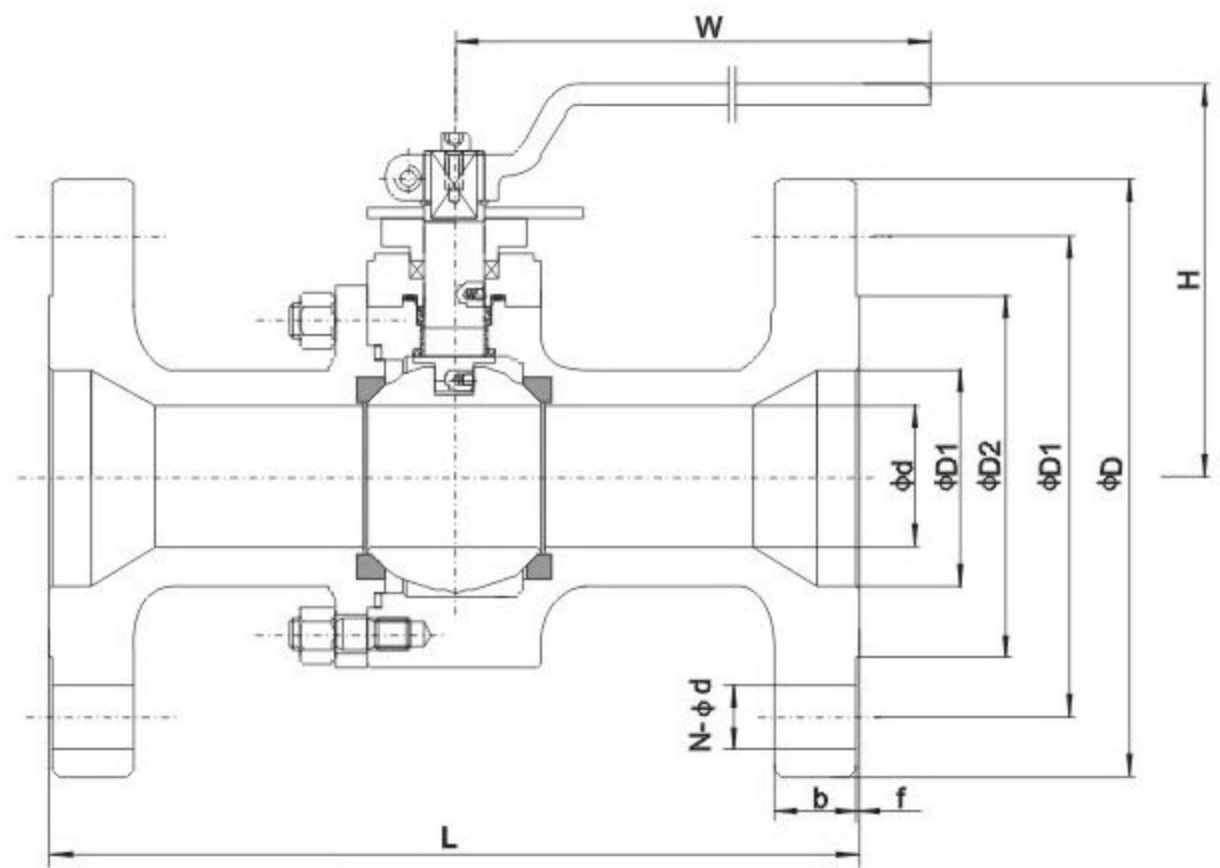

Floating forged steel ball valve

Pressure rating	Nominal Diameter		d	d1	Flanged		Butt welding	Raised face flange					W	Cast steel	Forged steel	Weight(kg)			
	Class	NPS			DN	L(RF)	L(RTJ)	L(BW)	D	D1	D2	f		b	N-Φ d	H	H	Cast steel	Forged steel
150		3/4" x 1/2"	20	13	19	117	-	152	100	70	43	2	10	4-Φ 16	140	80	78	△	△
		1" x 3/4"	25	19	25	127	-	165	110	79.5	51	2	11	4-Φ 16	140	86	82	△	△
		1 1/4" x 1"	32	25	32	140	-	178	115	89	64	2	11	4-Φ 16	180	98	95	△	△
		1 1/2" x 1 1/4"	40	32	38	165	-	190	125	98.5	73	2	13	4-Φ 16	180	106	100	△	△
		2" x 1 1/2"	50	38	50	178	191	216	150	120.5	92	2	14.5	4-Φ 19	200	133	128	8	△
		3" x 2"	80	50	75	203	216	283	190	152.5	127	2	17.5	4-Φ 19	300	138	137	14	△
		4" x 3"	100	75	100	229	241	305	230	190.5	157	2	22.5	8-Φ 19	650	175	148	24	△
		6" x 4"	150	100	150	267	279	403	280	241.5	216	2	24	8-Φ 22	800	235	223	41	△
	8" x 6"	200	150	201	292	305	419	345	298.5	270	2	27	8-Φ 22	1000	285	278	68	△	
300		3/4" x 1/2"	20	13	19	152	-	152	115	82.5	43	2	14.5	4-Φ 19	140	80	78	△	△
		1" x 3/4"	25	19	25	165	-	165	125	89	51	2	16	4-Φ 19	140	86	82	△	△
		1 1/4" x 1"	32	25	32	178	-	178	135	98.5	64	2	17.5	4-Φ 19	180	98	95	△	△
		1 1/2" x 1 1/4"	40	32	38	190	-	190	155	114.5	73	2	19.5	4-Φ 22	180	106	100	△	△
		2" x 1 1/2"	50	38	50	216	232	216	165	127	92	2	21	8-Φ 19	200	133	128	11	△
		3" x 2"	80	50	75	283	298	283	210	168.5	127	2	27	8-Φ 22	300	138	137	21	△
		4" x 3"	100	75	100	305	321	305	255	200	157	2	30.5	8-Φ 22	650	175	148	36	△
		6" x 4"	150	100	150	403	419	457	320	270	216	2	35	12-Φ 22	800	235	223	82	△
	8" x 6"	200	150	201	419	435	419	380	330	270	2	40	12-Φ 25	1000	285	278	126	△	
600		3/4" x 1/2"	20	13	19	190	-	190	115	82.5	43	7	16	4-Φ 19	140	78	68	△	△
		1" x 3/4"	25	19	25	216	-	216	125	89	51	7	17.5	4-Φ 19	180	80	76	△	△
		1 1/4" x 1"	32	25	32	229	-	229	135	98.5	64	7	21	4-Φ 19	200	110	106	△	△
		1 1/2" x 1 1/4"	40	32	38	241	-	241	155	114.5	73	7	22.5	4-Φ 22	250	115	110	△	△
		2" x 1 1/2"	50	38	50	292	295	292	165	127	92	7	26	8-Φ 19	300	135	128	△	△
		3" x 2"	80	50	75	356	359	356	210	168.5	127	7	32	8-Φ 22	650	152	140	△	△
	4" x 3"	100	75	100	432	435	432	275	216	157	7	38.5	8-Φ 25	800	224	213	△	△	

△ Please consult the factory:

Note: The weight value is only for flanged valve. Please consult our factory for higher nominal diameter or weight. Any modification to sizes H, H1 and weight will not be notified otherwise.